

Mulavirkjun 1 und 2

Francis-Spiralturbine / 2177 kW / 1051 kW

GLOBAL
HYDROENERGY

Standort / Location:

Iceland

Kunde / Client:

Orkuver

Inbetriebnahme Jahr / Commissioning Year:

2005

Projektleiter / Project manager

Thomas Jungwirth



Krafthaus
Power house



Elektrische Schaltanlage
Electronical control system

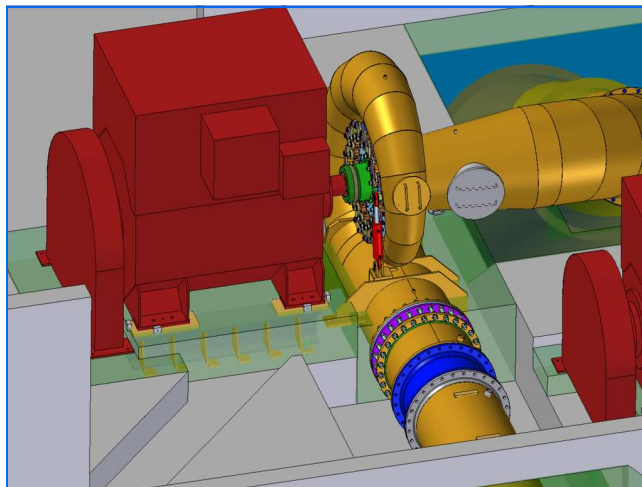

CAD-Modell 3D
CAD model 3D

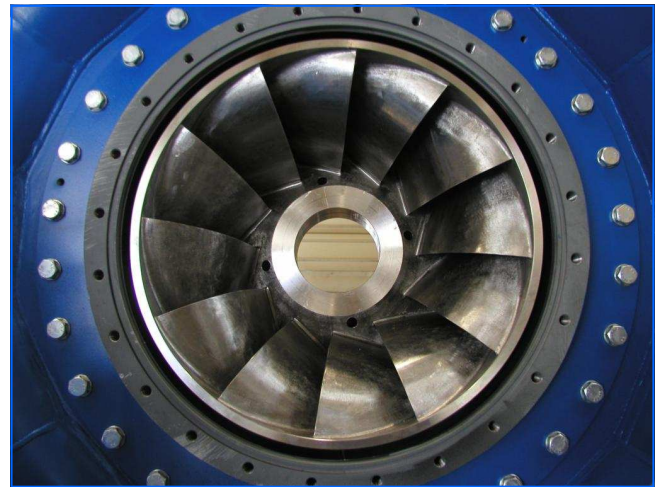

Francis-Laufrad
Francis runner

Lieferumfang / Scope of supply:

Turbine / Turbine ✓

Generator / Generator ✓

Turbinenregelung / Turbine Governor

NS Schaltanlage / LV switchgear ✓

MS Schaltanlage / MV switchgear

Hydraulikeinheit / Hydraulic unit ✓

Stahlwasserbau / Hydraulic steel structure ✓

Technische Daten / Technical data:

Leistung Turbine / Power turbine: 2177/1051 kW

Anzahl Turbinen / Number of turbine: 1

Anlagenleistung / Power plant: 2177/1051 kW

Fallhöhe / Head: 82 m

Durchfluss / Flow: 3,1/1,5 m³/sec

Drehzahl / Speed: 750/1000 rpm

Laufrad Ø / Runner diameter: 800/560 mm