

Standort / Location:

AUSTRIA

Kunde / Client:

BRANDSTETTER KW RAUDASCHL GmbH & CoKG

Inbetriebnahme Jahr / Commissioning Year:

2006

Projektleiter / Project manager

Thomas Jungwirth

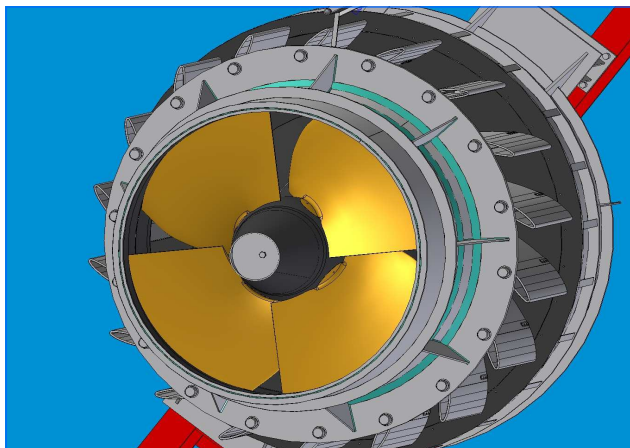

3D CAD Zeichnung Lauftrad
3D CAD drawing runner

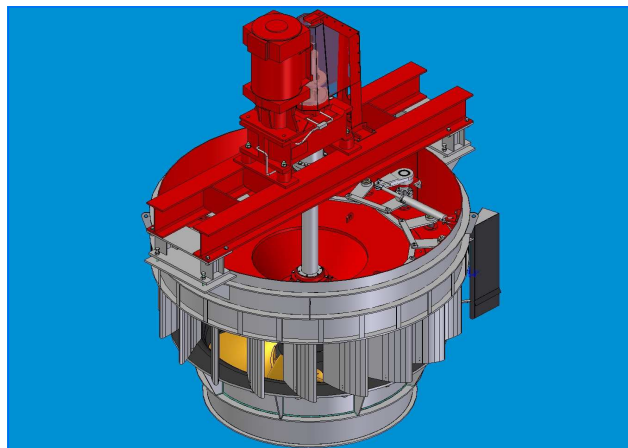

3D CAD Zeichnung Turbine
3D CAD drawing turbine



Stauklappe
Air vane



Transport Turbine
Transport turbine

Lieferumfang / Scope of supply :

Turbine / Turbine	✓
Generator / Generator	✓
Turbinenregelung / Turbine Governor	✓
NS Schaltanlage / LV switchgear	✓
MS Schaltanlage / MV switchgear	✓
Hydraulikeinheit / Hydraulic unit	✓
Stahlwasserbau / Hydraulic steel structure	✓

Technische Daten / Technical data:

Leistung Turbine / Power turbine:	320 kW
Anzahl Turbinen / Number of turbine:	1
Anlagenleistung / Power plant:	320 kW
Fallhöhe / Head:	1,8 m
Durchfluss / Flow:	20 m³/sec
Drehzahl / Speed:	190 rpm
Lauftrad Ø / Runner diameter:	2820 mm